

## INSTRUCTIONS FOR FITTING THE LEAP FROG 48/96 SMPTE/MIDI/CAN/REMOTES UPGRADE KIT

### WARNING

**Unplug the power supply unit from the desk before removing any covers.**

**Appropriately qualified persons only must undertake servicing of equipment.**

**Zero 88 cannot accept responsibility for repairs or modifications that are not competently executed and in accordance with service or upgrade information.**

**Before attempting to fit the Leap Frog 48/96 SMPTE/MIDI/CAN/Remotes Upgrade Kit to your Leap Frog 48/96 lighting desk please read these instructions carefully.**

**Electrostatic discharge (ESD) can damage the circuit boards and other components. The procedure described below should be carried out at an ESD workstation only. If such a station is not available, wearing an antistatic wrist strap and attaching it to a metal part of the desk chassis can provide some ESD protection.**

#### **Upgrade kit contents:**

- |   |     |
|---|-----|
| 1) Leap Frog 48/96 SMPTE/MIDI/CAN/Remotes upgrade PCB | x 1 |
| 2) Spacer M4 metal hexagonal male-female 42mm         | x 3 |
| 3) Screw M3 x 8mm plastite black                      | x 2 |
| 4) Washer M3 internal toothlock black                 | x 2 |
| 5) Connector identification label                     | x 1 |

Zero 88 reserves the right to make changes to the equipment described in this manual without prior notice.

This equipment is designed for professional stage lighting control, and is unsuitable for any other purpose. It should be used by, or under the supervision of, appropriately qualified or trained persons only. E & OE

Servicing of this equipment should be attempted by suitably qualified persons only.

#### **Zero 88**

Usk House, Llantarnam Park, Cwmbran, NP44 3 HD U.K.  
Tel: +44 (0) 1633 838088 Fax: +44 (0) 1633 867880  
Email: [sales@zero88.com](mailto:sales@zero88.com) Web: [www.zero88.com](http://www.zero88.com)

## Fitting Instructions

1. Ensure that the desk is switched off. Disconnect the power supply unit and all cables. Turn the desk upside down and rest on suitable supports (e.g. foam rubber). **Do not rest the desk on the control knobs as this may damage them.**
2. Remove the five screws that secure the blanking panel to the rear of the desk and remove the blanking panel (see fig 1).

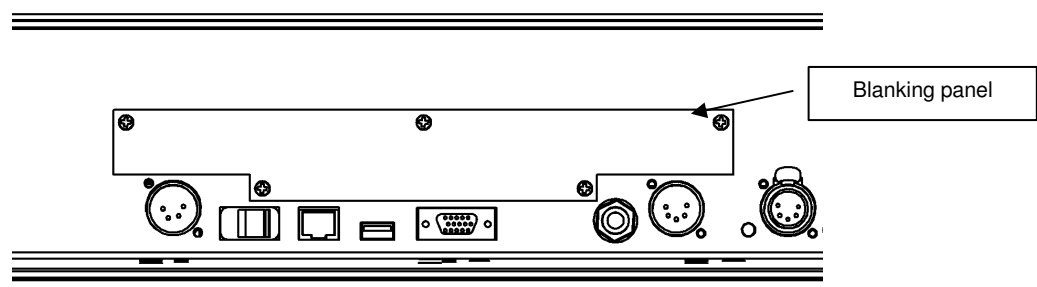

Fig 1 – Blanking Panel

3. Remove the four screws, two either side of the desk, that fix the base to the side panels (see fig 2). Retain the screws. Lift the base slightly and then pull it towards the rear of the desk so that it comes out of the groove in the underside of the desk.

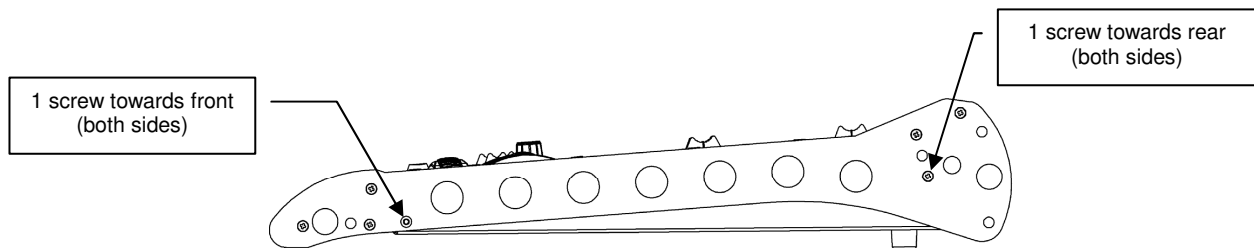

Fig 2 – Base panel fixing screws position

Zero 88 reserves the right to make changes to the equipment described in this manual without prior notice.

This equipment is designed for professional stage lighting control, and is unsuitable for any other purpose. It should be used by, or under the supervision of, appropriately qualified or trained persons only. E & OE

Servicing of this equipment should be attempted by suitably qualified persons only.

### **Zero 88**

Usk House, Llantarnam Park, Cwmbran, NP44 3 HD U.K.  
Tel: +44 (0) 1633 838088 Fax: +44 (0) 1633 867880  
Email: [sales@zero88.com](mailto:sales@zero88.com) Web: [www.zero88.com](http://www.zero88.com)

- Remove and retain the three screws A, B and C shown in fig 3. Replace these screws with the three hexagonal metal spacers supplied.

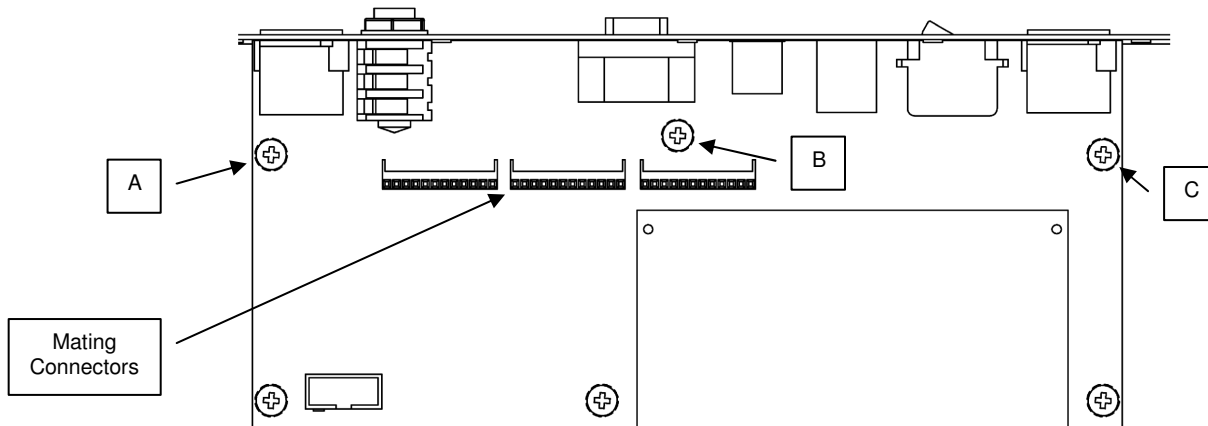

**Fig 3 – Fixing holes used and mating connector positions**

- Before fitting the SMPTE/MIDI/CAN/Remotes Upgrade PCB, make sure that the plastic nuts and washers have been removed from the two audio jack connectors. Retain these nuts and washers. Carefully assemble the SMPTE/MIDI/CAN/Remotes Upgrade PCB by poking the connectors through the holes in the rear of the metal base, slightly flexing the three long pin connectors so that they line up with the three mating connectors on the processor PCB and pushing the connectors together. Fit the previously retained screws A, B and C through the fixing holes in the SMPTE/MIDI/CAN/Remotes Upgrade PCB and into the hexagonal metal spacers (see fig 4).

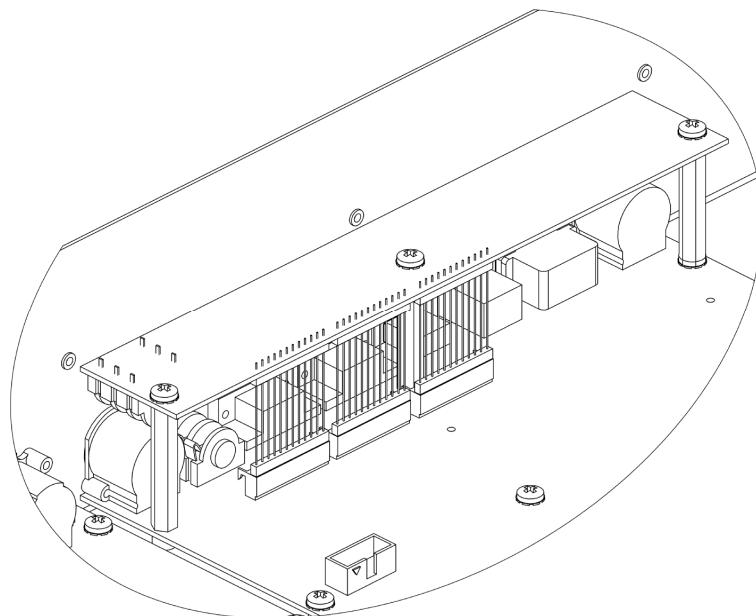

**Fig 4 – Assembled SMPTE/MIDI/CAN/Remotes Upgrade PCB**

Zero 88 reserves the right to make changes to the equipment described in this manual without prior notice.

This equipment is designed for professional stage lighting control, and is unsuitable for any other purpose. It should be used by, or under the supervision of, appropriately qualified or trained persons only. E & OE

Servicing of this equipment should be attempted by suitably qualified persons only.

**Zero 88**  
 Usk House, Llantarnam Park, Cwmbran, NP44 3 HD U.K.  
 Tel: +44 (0) 1633 838088 Fax: +44 (0) 1633 867880  
 Email: [sales@zero88.com](mailto:sales@zero88.com) Web: [www.zero88.com](http://www.zero88.com)



6. Fit the retained plastic nuts and washers to the two audio jack connectors. Fit the two M3 plastite screws and toothlock washers to the XLR3M SMPTE connector.
7. Lower the base panel into position and slot it into the groove on the rear of the front panel assembly, being careful not to trap any wires, and secure the base to sides using the four screws removed initially.
8. Affix the connector identification label to exterior of base above connectors.

---

Zero 88 reserves the right to make changes to the equipment described in this manual without prior notice.

This equipment is designed for professional stage lighting control, and is unsuitable for any other purpose. It should be used by, or under the supervision of, appropriately qualified or trained persons only. E & OE

Servicing of this equipment should be attempted by suitably qualified persons only.

**Zero 88**

Usk House, Llantarnam Park, Cwmbran, NP44 3 HD U.K.  
Tel: +44 (0) 1633 838088 Fax: +44 (0) 1633 867880  
Email: [sales@zero88.com](mailto:sales@zero88.com) Web: [www.zero88.com](http://www.zero88.com)